

**ALUMINIUM SUPPORT SYSTEM FOR  
RAINSCREEN CLADDING  
XKELEX X-CS19**



**LEGEND**

- 1. Steel Stud (16 GA typical)
- 2. X-Z19PF profile
- 3. A/V Barrier
- 4. Exterior Wall
- 5. T U anchor
- 6. Level Screw
- 7. X-TB19 Spacer
- 8. Exterior panel
- 9. X-CL19 fixed bracket

**CONTENT**

- CS19-00 Xkelex System detail sheet
- CS19-01 Profiles
- CS19-02 Building Elevation
- CS19-03 Horizontal Panel Joint
- CS19-04 Horizontal Mid Panel
- CS19-05 Window Jamb
- CS19-06 Door Jamb
- CS19-07 Inside Corner
- CS19-08 Outside Corner
- CS19-09 Window Head
- CS19-10 Vertical Panel Joint
- CS19-11 Window Sill
- CS19-12 Base Detail

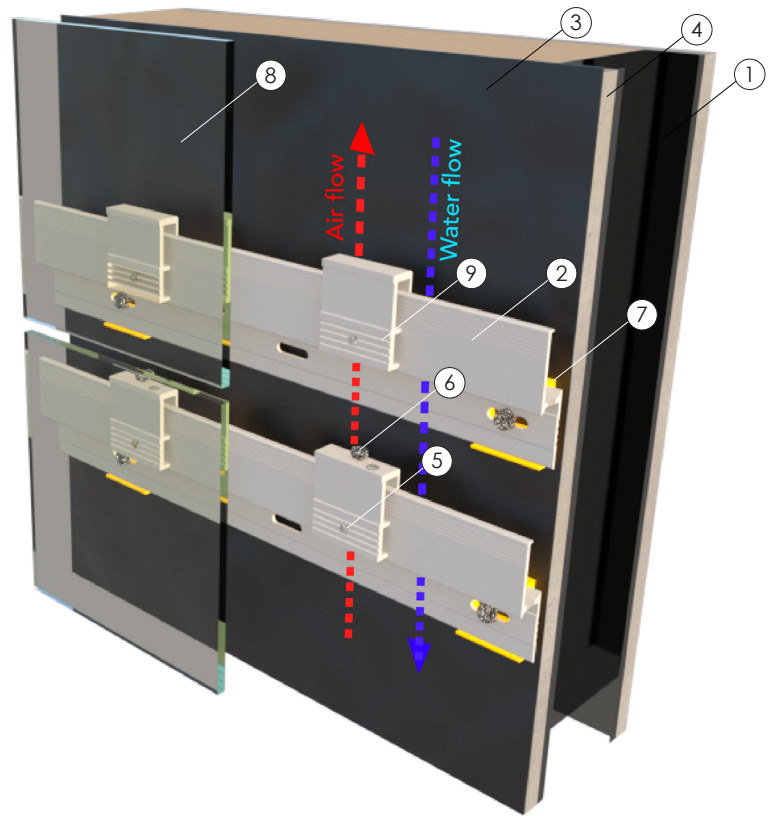

NOTES:

---



---



---



---



SYSTEM:

**X-CS19**

DETAIL:

**XKELEX SYSTEM**

DETAIL SHEET:

**CS19-00**

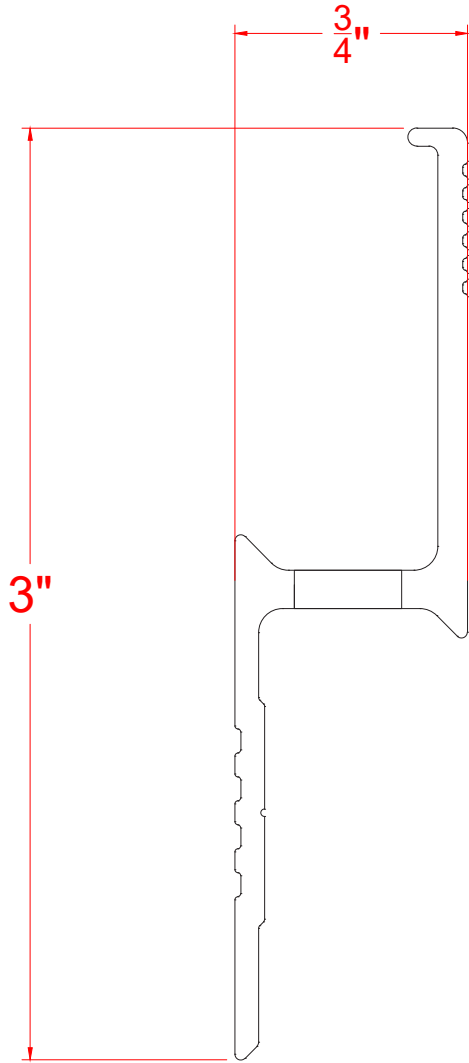

X-Z19PF PROFILE

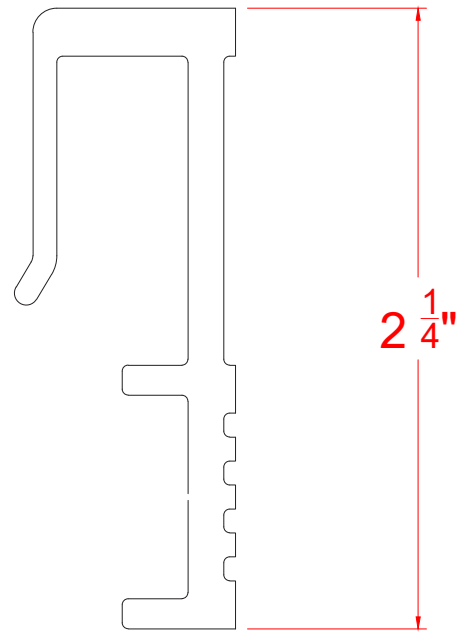

X-CL19 BRACKET

NOTES:



SYSTEM:

X-CS19

DETAIL:

PROFILES

DETAIL SHEET:

CS19-01



NOTES:



SYSTEM:

X-CS19

DETAIL:

BUILDING ELEVATION

DETAIL SHEET:

CS19-02

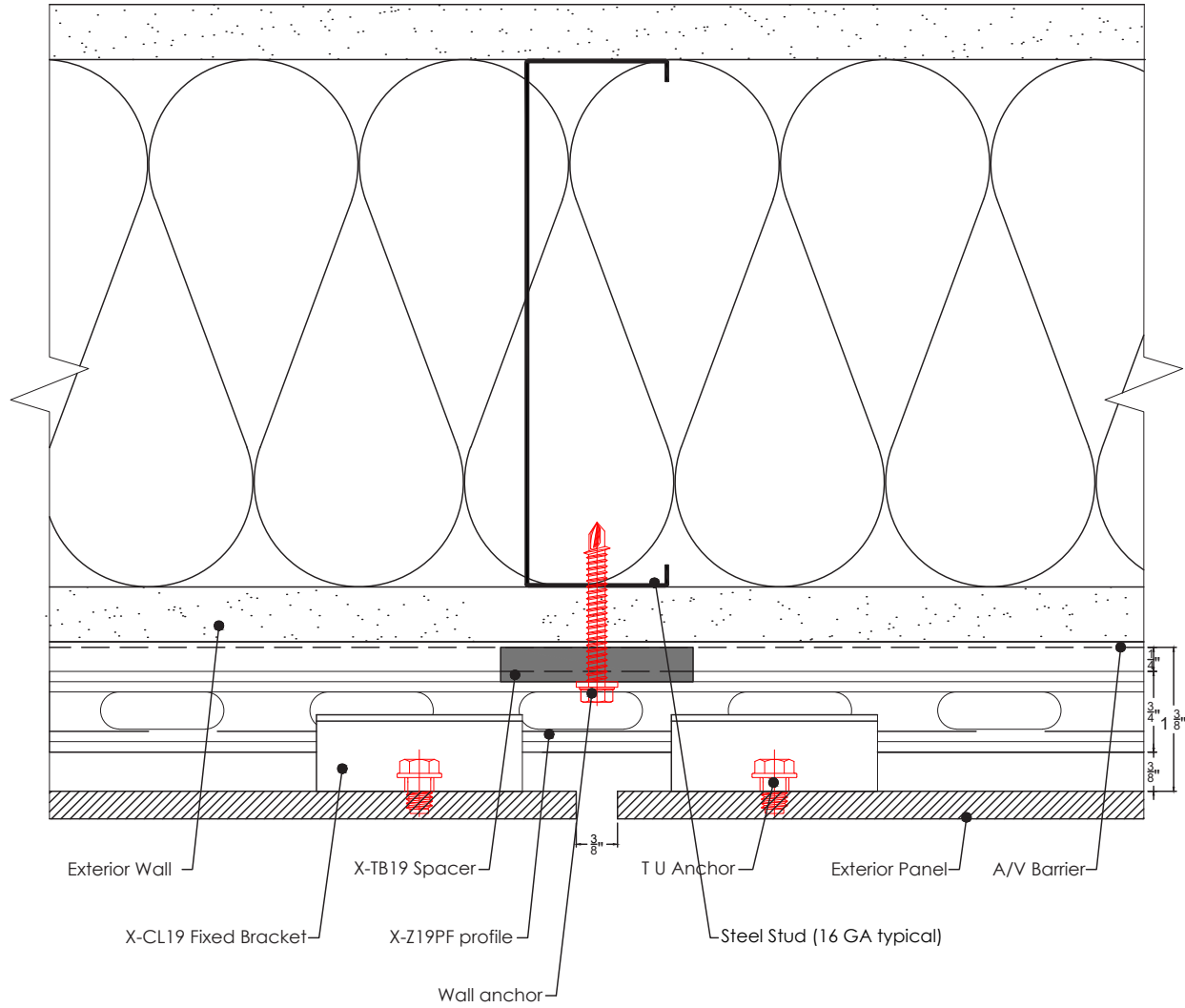

NOTES:



SYSTEM:

X-CS19

DETAIL:

PLAN VIEW VERTICAL PANEL JOINT

DETAIL SHEET:

CS19-03

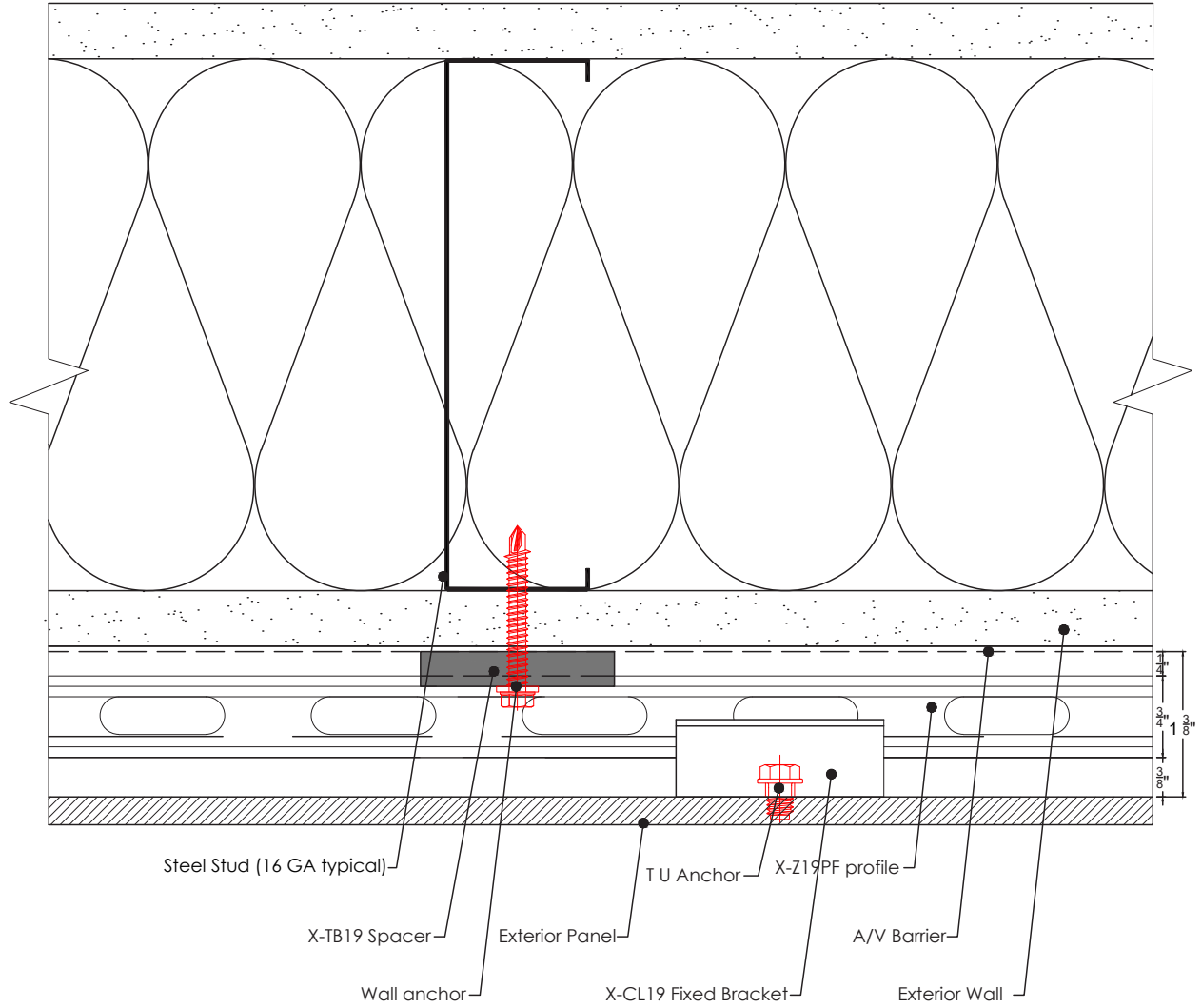

NOTES:



SYSTEM:

X-CS19

DETAIL:

PLAN VIEW MID PANEL

DETAIL SHEET:

CS19-04

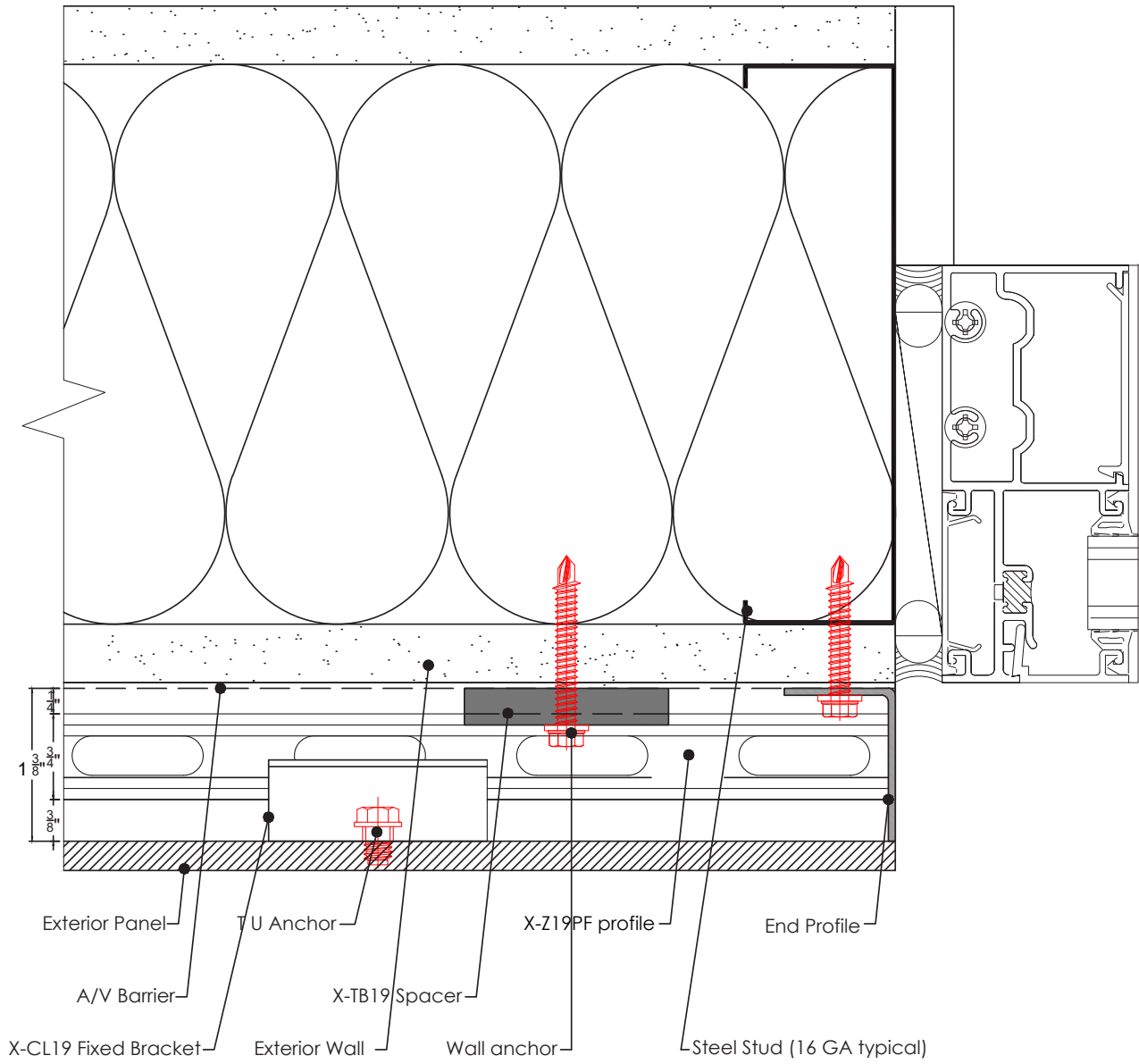

NOTES:



SYSTEM:

X-CS19

DETAIL:

PLAN VIEW WINDOW JAMB

DETAIL SHEET:

CS19-05

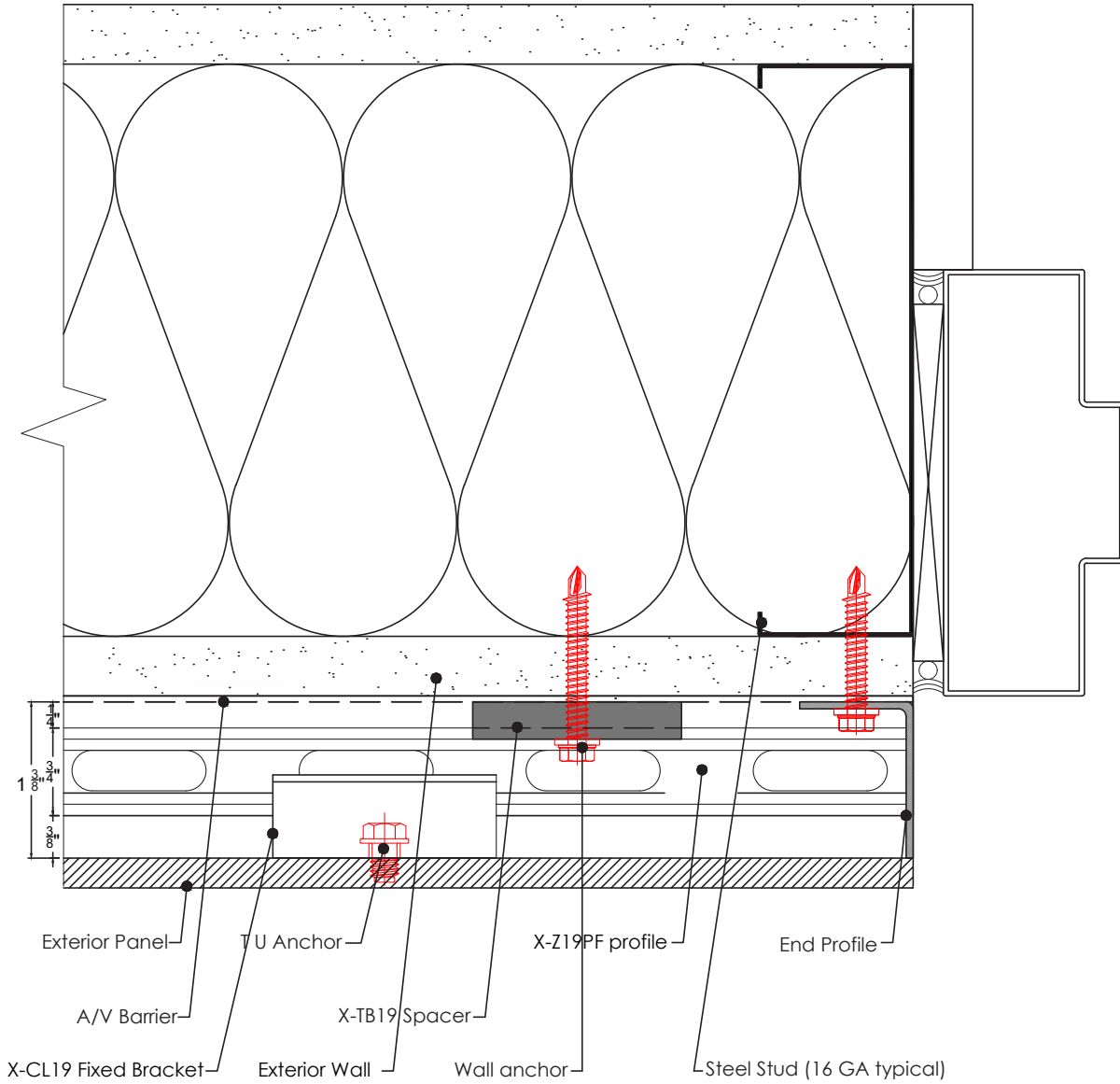

NOTES:



SYSTEM:

X-CS19

DETAIL:

PLAN VIEW DOOR JAMB

DETAIL SHEET:

CS19-06

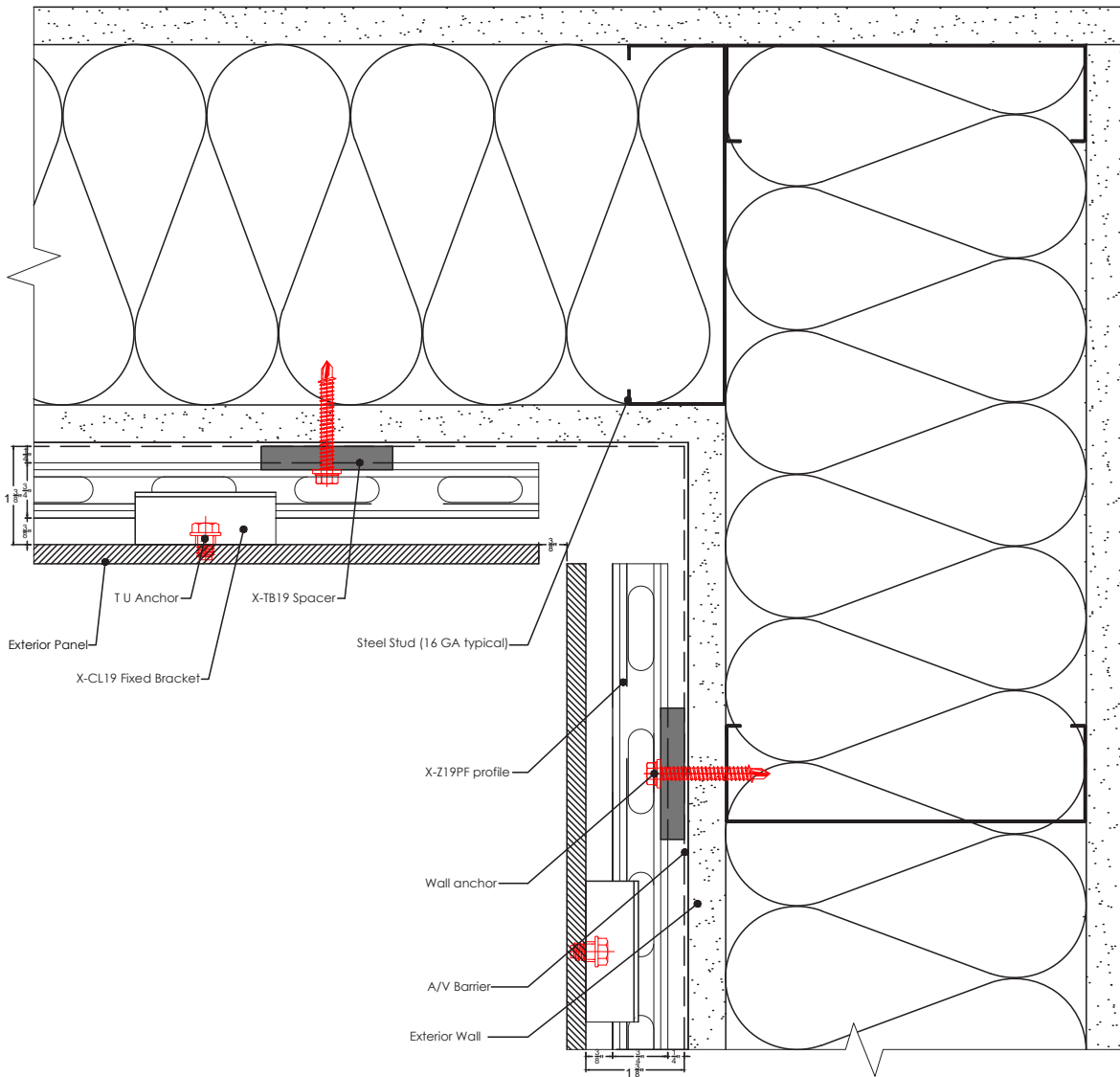

NOTES:

---



---



---



---



SYSTEM:

X-CS19

DETAIL:

PLAN VIEW INSIDE CORNER

DETAIL SHEET:

CS19-07



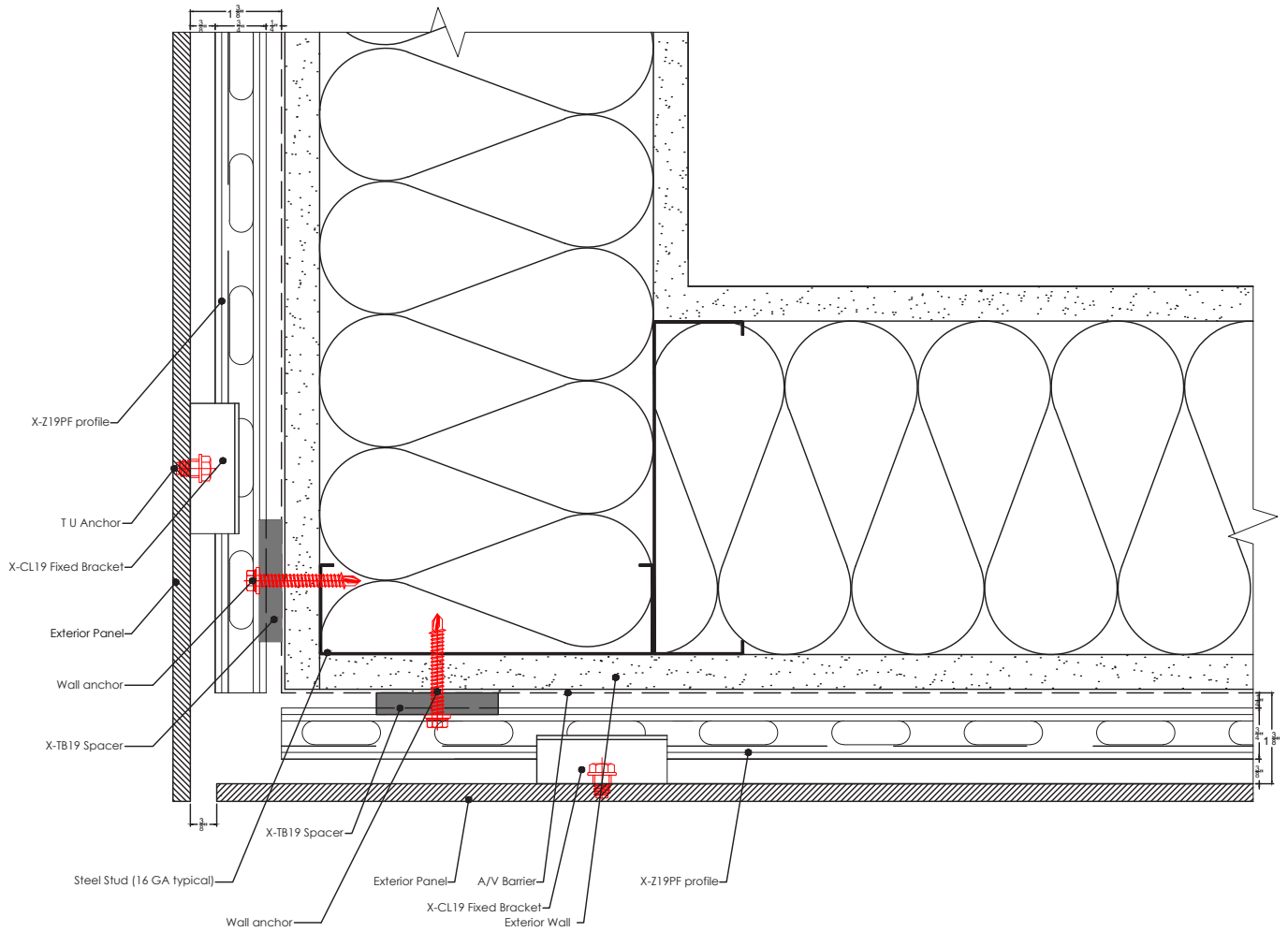

NOTES:

---



---



---



---



---



SYSTEM:

X-CS19

DETAIL:

PLAN VIEW OUTSIDE CORNER

DETAIL SHEET:

CS19-08

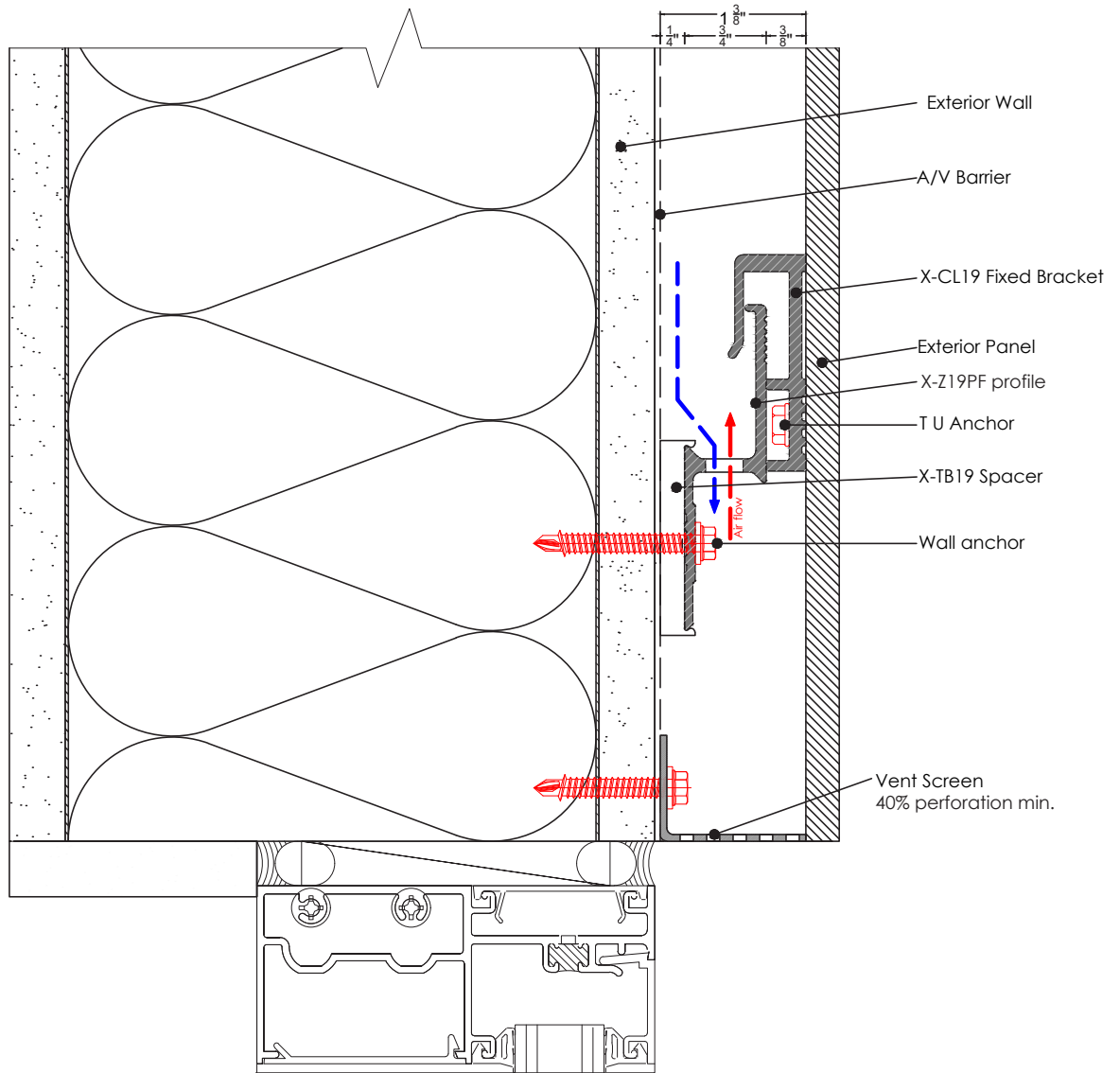

NOTES:



SYSTEM:

X-CS19

DETAIL:

SECTION WINDOW HEAD

DETAIL SHEET:

CS19-09

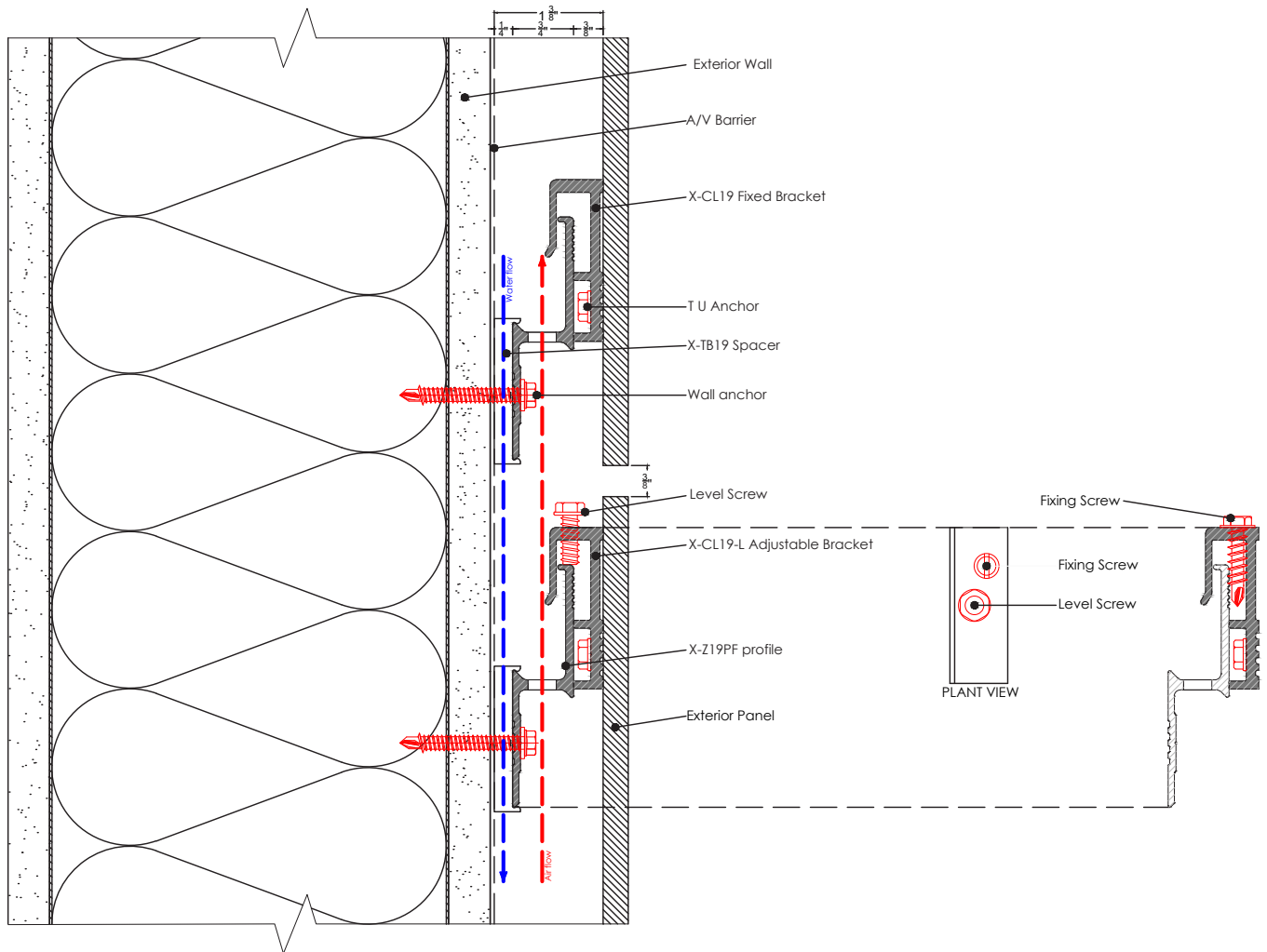

NOTES:



SYSTEM:

X-CS19

DETAIL:

SECTION HORIZONTAL PANEL JOINT

DETAIL SHEET:

CS19-10

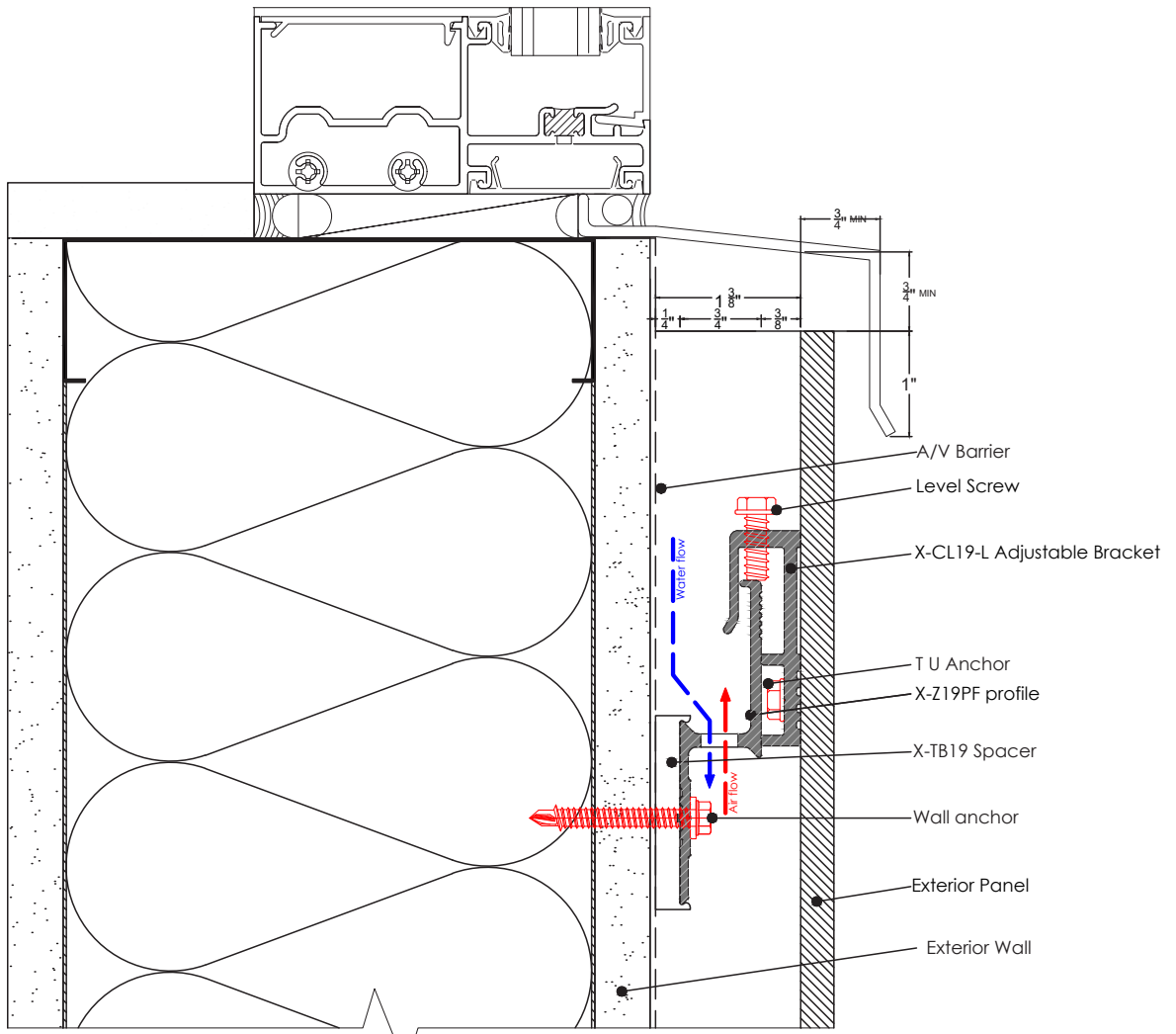

NOTES:

---



---



---



---



SYSTEM:

X-CS19

DETAIL:

SECTION WINDOW SILL

DETAIL SHEET:

CS19-11

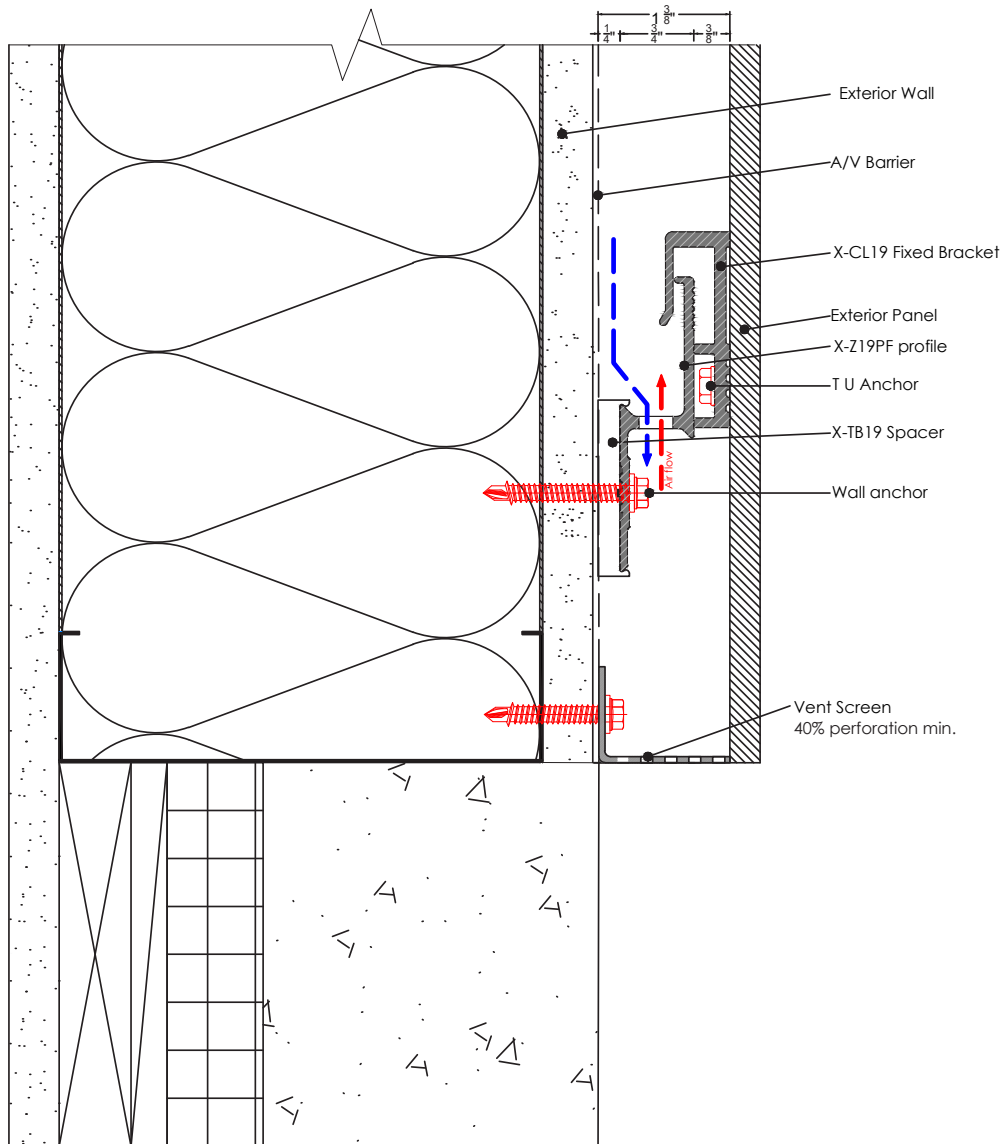

NOTES:



SYSTEM:

X-CS19

DETAIL:

SECTION BASE DETAIL

DETAIL SHEET:

CS19-12